

PD 8 Shoring System

The cost-effective shoring for slab tables and high leg loads

Product Brochure – Edition 05/2017



Content

System advantages		System overview	
5	PD 8 Shoring System	12	PD 8 Shoring System at a glance
6	Quickly and continuously adaptable		
8	High load-bearing capacity		
10	Large units easily moved		
		Standard applications	
		14	Assembling the shoring
		16	Execution details

Edition 05 | 2017

Publisher

PERI GmbH
Formwork Scaffolding Engineering
Rudolf-Diesel-Strasse 19
89264 Weissenhorn
Germany
Phone +49 (0)7309.950-0
Fax +49 (0)7309.951-0
info@peri.de
www.peri.de

Project examples

- 18 PD 8 Shoring System in use
- 20 Application examples in multi-storey and industrial buildings
- 22 Application examples in infrastructure construction

Components

- 24 Components

Important notes

All current safety regulations and guidelines applicable in those countries where our products are used must be observed.

The photos shown in this brochure feature construction sites in progress. For this reason, safety and anchor details in particular cannot always be considered as conclusive or final. These are subject to the risk assessment carried out by the contractor.

In addition, computer graphics are used which are to be understood as system representations. For ensuring a better understanding, these and the detailed illustrations shown have been par-

tially reduced to show certain aspects. The safety installations which have possibly not been shown in these detailed descriptions must nevertheless be available. The systems or items shown might not be available in every country.

Safety instructions and load specifications are to be strictly observed at all times. Separate structural calculations are required for any deviations from the standard design data.

The information contained herein is subject to technical changes in the interests of progress. Errors and typographical mistakes reserved.



PD 8 Shoring System

The cost-effective shoring for slab tables and high leg loads

PD 8 Shoring is predestined for use under slab tables – in particular, due to its large spindle extensions, the system can be quickly adapted to accommodate different slab heights as well as being lowered for moving under large beams.

The PD 8 is a cost-effective system for the erection of supporting frame structures in formwork construction. The

frames consist of welded, fully galvanized tubular steel framework elements and are supplemented with spindles at the head and base thus forming rectangular or square shoring towers or suspended shear frames that can be joined together. Thereby, the basic dimensions under the slab tables range from 1.50 m x 1.25 m up to 1.50 m x 3.50 m. The shoring system can be used with up to 73 kN per leg for high leg loads and for large room heights.

All heights can be incrementally realized using just the Frames R 150 and R 110 and spindles. The two frames are tightly connected to each other by means of diagonal bracing.

Quickly and continuously adaptable

with only 2 frame heights and large spindle extensions

High load-bearing capacity

with up to 73 kN leg load and for large slab heights

Large units easily moved

horizontally with a Trolley and Winch, and vertically using the Lifting Fork



Quickly and continuously adaptable

with only 2 frame heights and large spindle extensions

The PERI PD 8 Shoring System has only a minimum of system components: the main components are two frames, head and base spindles as well as diagonal bracing.

PD 8 shoring can be flexibly used with its numerous frame combinations and diagonal bracing to accommodate different heights and ground plans thus making it easily geometrically adaptable for a wide range of projects. With only two frame sizes – the 110 cm high Frame R 110 and 150 cm high Frame R 150 – and spindle extensions up to 176 cm, virtually all heights can be continuously adjusted. In addition, the large adjustment range of the spindles provides sufficient lowering height for moving under beams or allowing simple adaptation in case of any unevenness within the shoring contact area.

PD 8 Diagonal Braces with dimensions ranging from 125 cm to 350 cm ensure optimal ground plan adjustments in the longitudinal direction of the shoring tower.

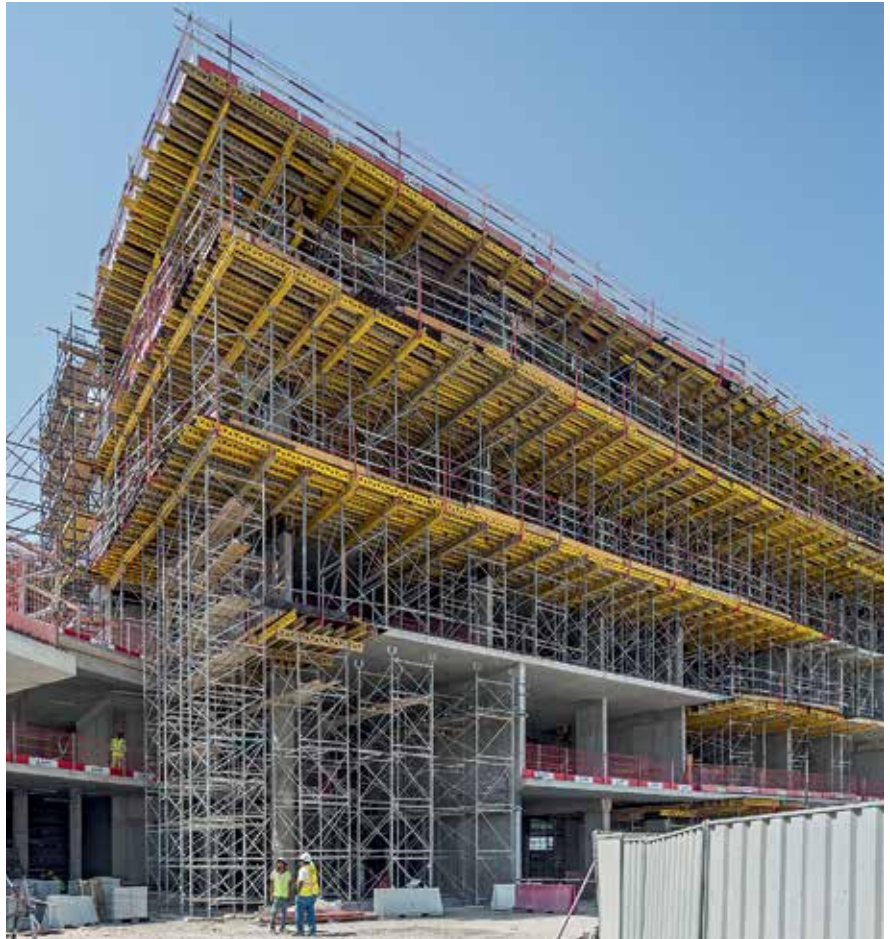

The flexible system can be easily adjusted also for varying support heights – here from 3.30 m through to 11.80 m.

Individual towers can be assembled to form shear frames without requiring any tube couplings. This secures the towers against tilting during assembly and helps to constantly maintain the spacing between the towers.

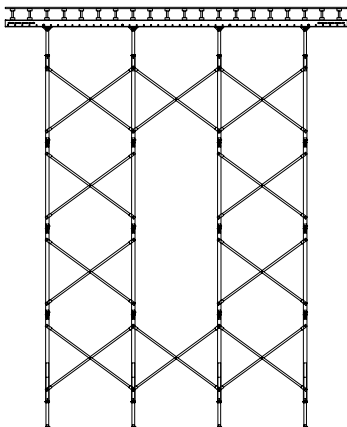

Adaptation in horizontal levels is possible through different diagonal bracing lengths and the distance of the frames to each other.

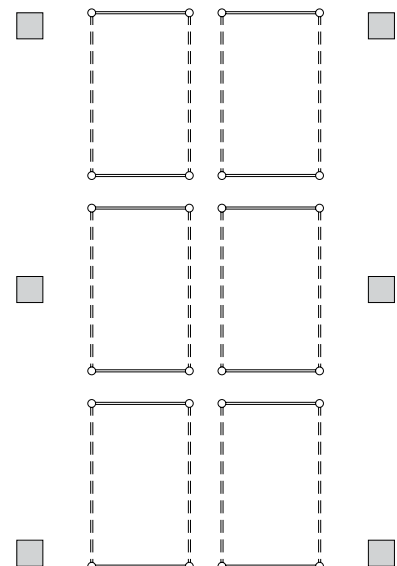
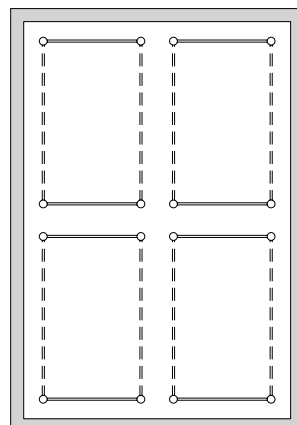

Overview of PD 8 system components

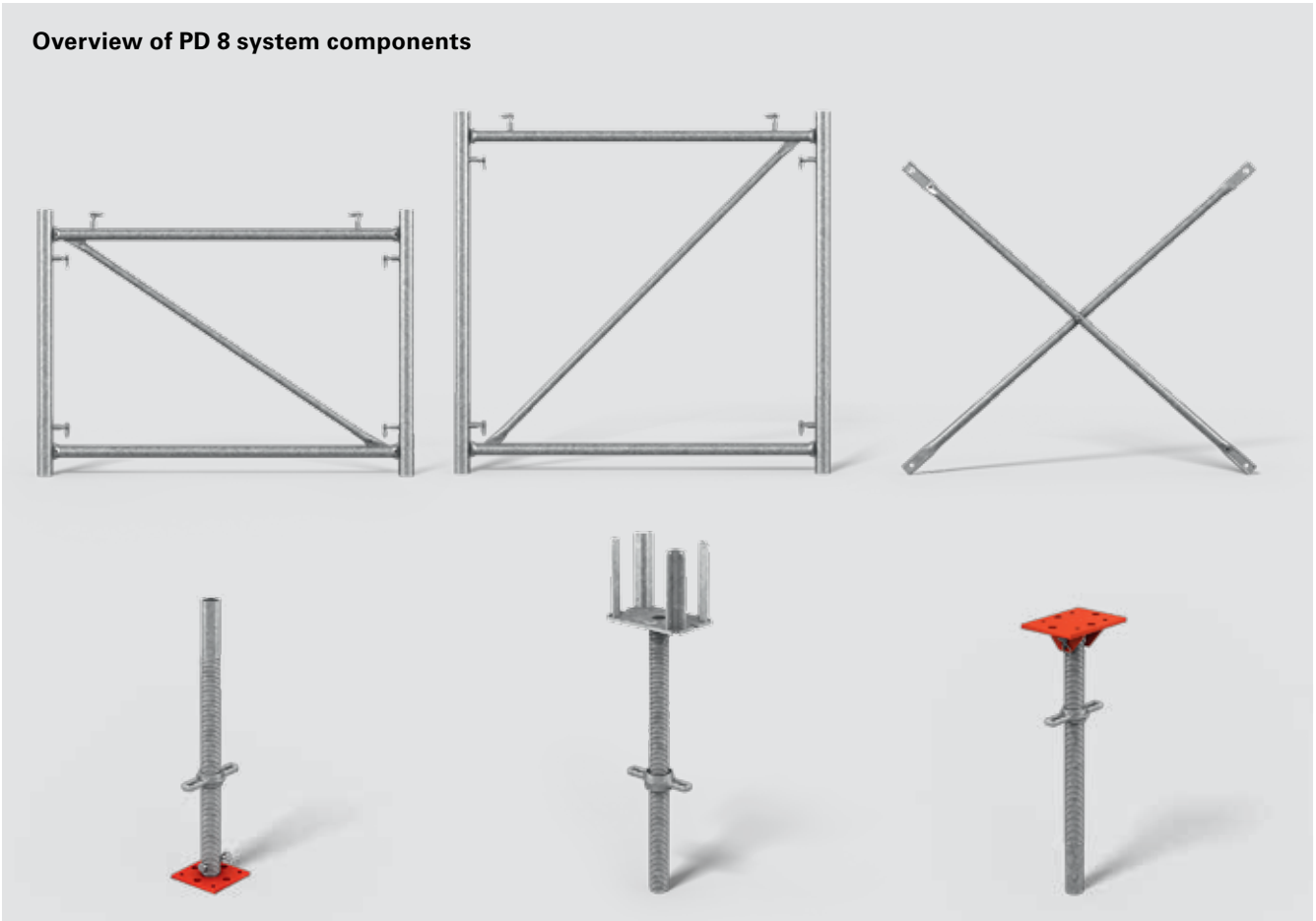

The maximum spindle extension length is 176 cm.

The shoring can be quickly adapted to suit different slab heights and is also very suitable for moving under large beams.

The PD 8 system is a cost-effective solution especially for use under slab tables.



High load-bearing capacity

providing up to 73 kN leg load as well as being used for large slab heights

With the PD 8 Shoring System, large support heights and moving units can be cost-effectively realized.

In the standard application, load-bearing capacities of up to 73.0 kN per leg are possible, dimensioned according to the current valid shoring standard DIN EN 12812 whilst taking into account real construction site conditions such as wind and inclined shoring.

If required, dimensioning outside of the standard application is also possible.

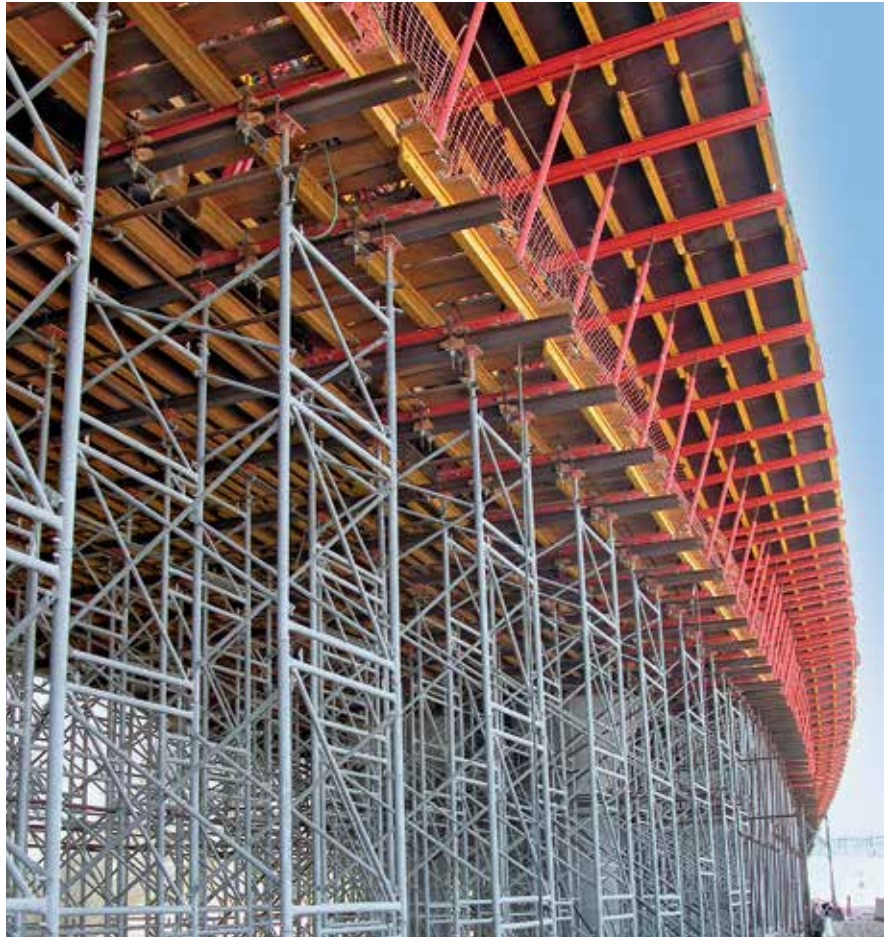

Optimal height adjustment with PD 8 Frames R 150 and R 110 for a bridge superstructure.



For the construction of this storage facility, 10.50 m high PD 8 Shoring with SRZ Steel Walers as main beams and VT 20 Formwork Girders as cross beams was used.



For this tunnel construction, the PD 8 System supports slabs with a slab thickness of up to 1.50 m.



Large units easily moved

horizontally with a Trolley and Winch, and vertically using the Lifting Fork



PD 8 shoring can be horizontally moved both easily and quickly using the Trolley and Winch.

Large wheels on the Trolley and Winch allow the PD 8 shoring to be easily moved also on uneven surfaces. Depending on the spindle extension, the frame of the PD 8 system can be accommodated in the bottom or top support. The permissible load-bearing capacity of the Trolley and Winch is 1000 kg.

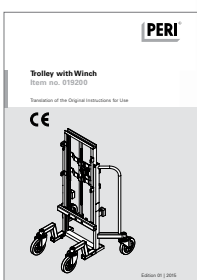

The corresponding PERI Instructions for Use must be observed for all moving equipment.

The PERI Lifting Fork facilitates moving by crane from floor to floor. The compensation mechanism in the Lifting Fork avoids the need to re-attach the lifting chains.

For fast transportation into the next storey, PERI Lifting Forks are used. It is always suspended in a horizontal position on the crane, when unloaded as well as with a slab table, thus ensuring a high level of safety.

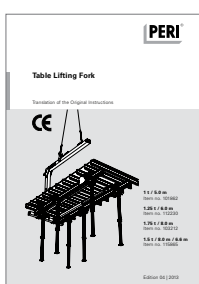
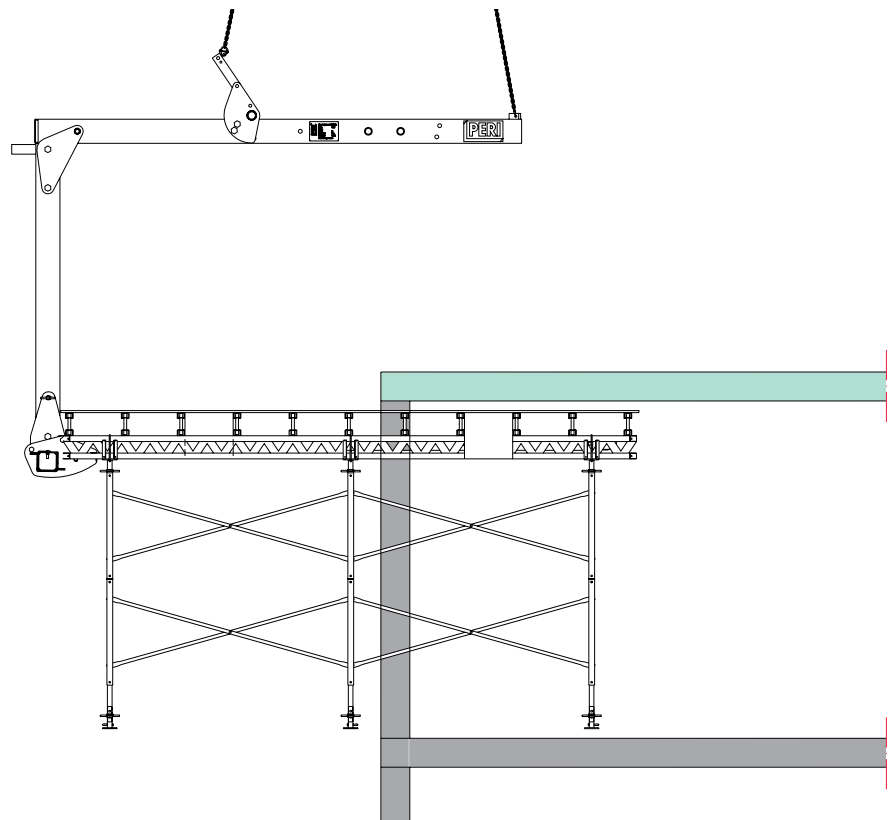

The corresponding PERI Instructions for Use must be observed for all moving and lifting equipment.

PD 8 Shoring System at a glance



The following pages describe standard applications such as shoring assembly and selected execution details. The explanations show important basic principles but do not make any claims regarding completeness.

All detailed specifications as well as any possible country-specific data can be found in the Instructions for Assembly and Use. Furthermore, the corresponding Instructions for Use must also be observed.

Assembling the shoring

Basic assembly, assembly of the second level, head area

Basic assembly

The PD 8 shoring is normally mounted in a vertical position on the specified assembly area. A crane is not required for the assembly but can be used to facilitate working procedures.

After mounting the base spindles on the frame (Detail A), the frame components are set up vertically according to specification. The Diagonal Braces DK are subsequently mounted on the self-locking pivots of the frames (Detail B).

In order to align the PD 8 Frames at right angles, a horizontal Diagonal Brace can be mounted. The frames can then be precisely aligned with the spindles to suit the required height.

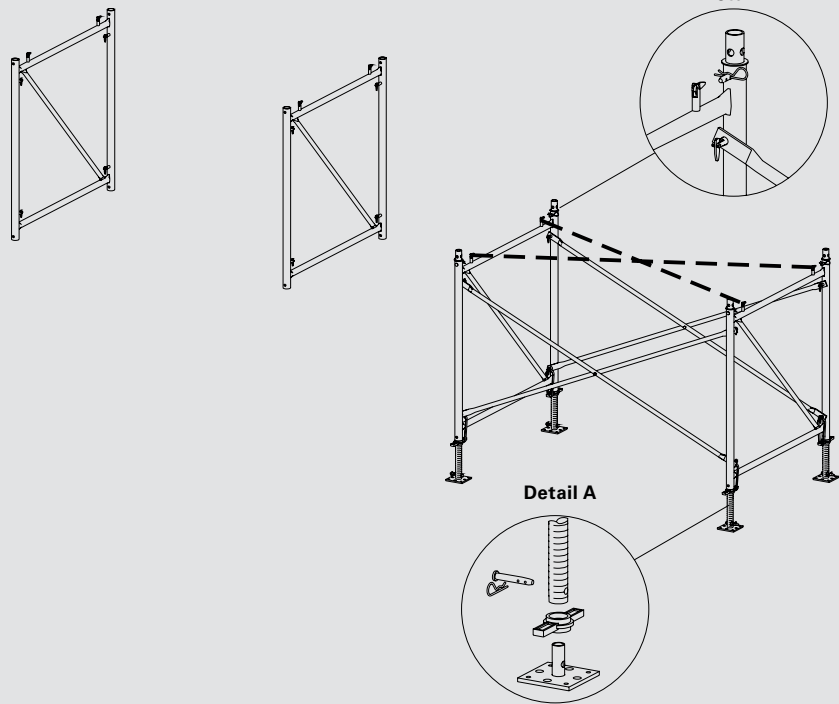

Assembly of the second level

Additional PD 8 Frames are to be assembled with the help of a working platform. The frames are tightly connected to each other by means of connectors, bolts and cotter pins (see Detail C). Alternatively, the frame units can also be pre-assembled and be completely moved with the crane.

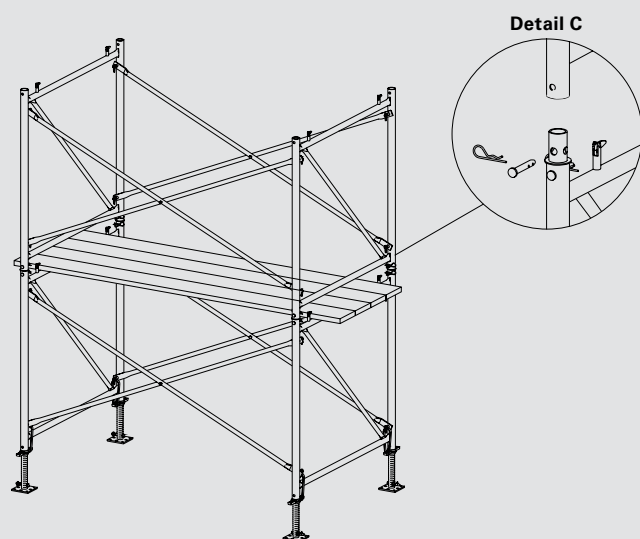

Head area

After reaching the required assembly height, head spindles are installed (see Detail D). The standard configuration consists of spindle tubes and head plates. Alternatively, the Crosshead Spindle can be used which serves as a support for up to two GT 24 or VT 20 Formwork Girders.

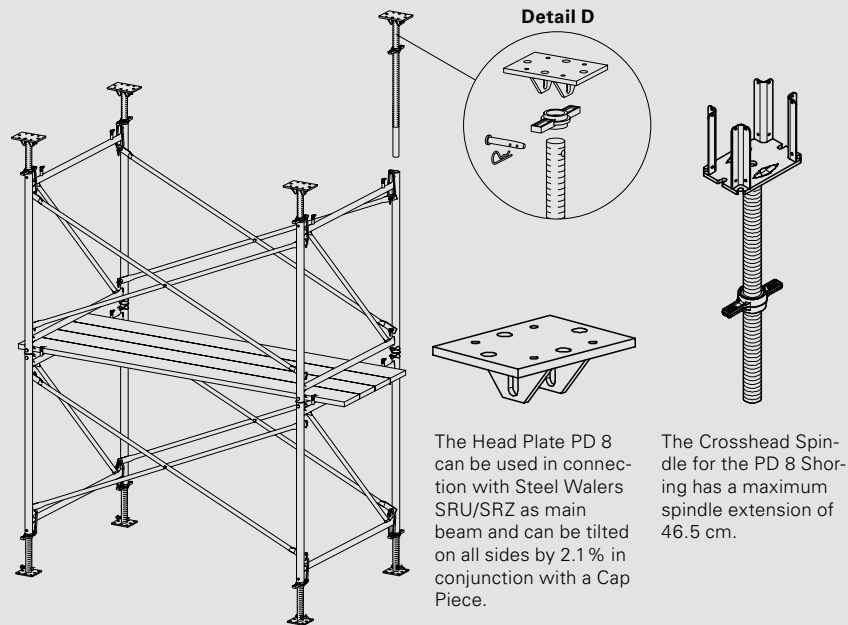

Basic assembly of the PD 8 Shoring can be carried out manually.

Execution details

Accessories for moving with the Lifting Fork and the crane suspension as well as for ensuring work safety

Girder Strap TB

If the Formwork Girder GT 24 is used as an individual main beam, it is to be fixed to the head plate by means of the girder strap.

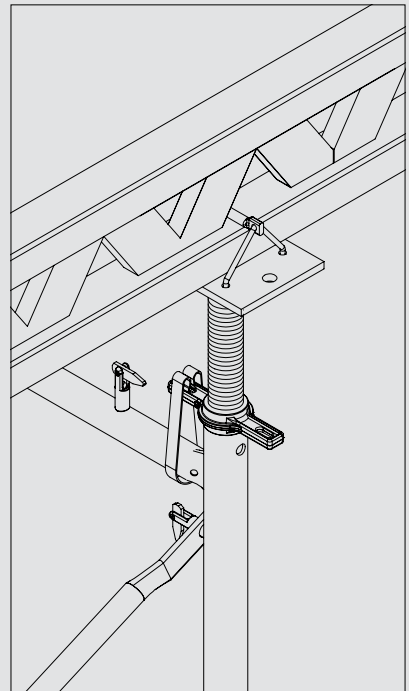
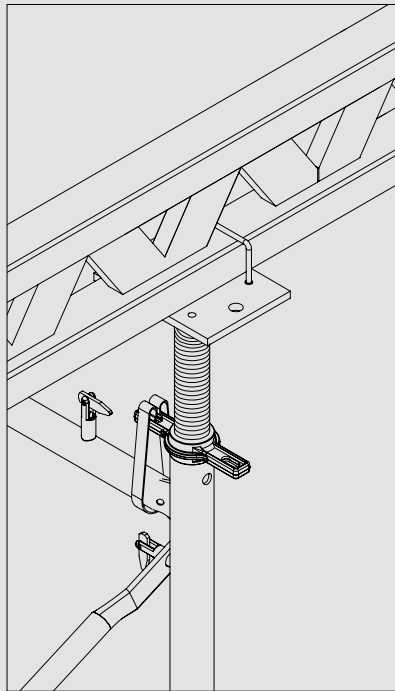

Double Girder Strap

When two Formwork Girders GT 24 are used as a twin main girder, yoke plates, yoke clamps and cam nuts serve to connect the girders to the head plate.

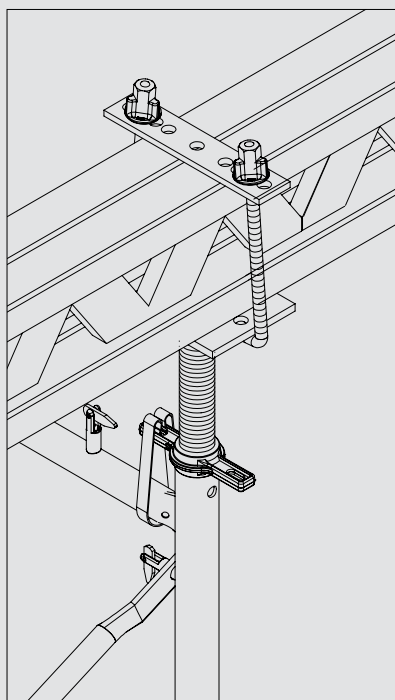

Spindle in connection with steel walers

When using Steel Walers SRU/SRZ as main beams, cross straps, bolts and nuts are used.

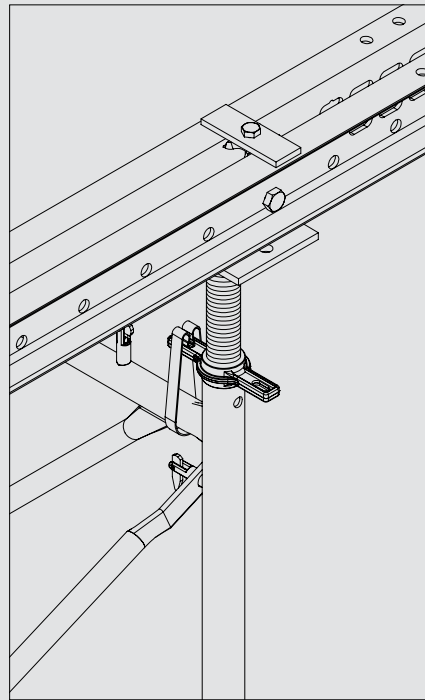

Guardrails on the edge table

The guardrails consist of the Guardrail Holder GT 24 / VT 20, the Guardrail Post SGP and guardrail boards provided by the contractor. Guardrails are pre-assembled on the ground.

For mounting on the main beam, the guardrail holder is pushed upwards onto the main beam using the square pipe. For assembly on the cross beam, the guardrail holder must be pushed downwards onto the main beam with the square pipe so that the same guardrail height is achieved on the longitudinal and front sides. The guardrail holder is secured with bolts and cotter pins before the guardrail post is installed.

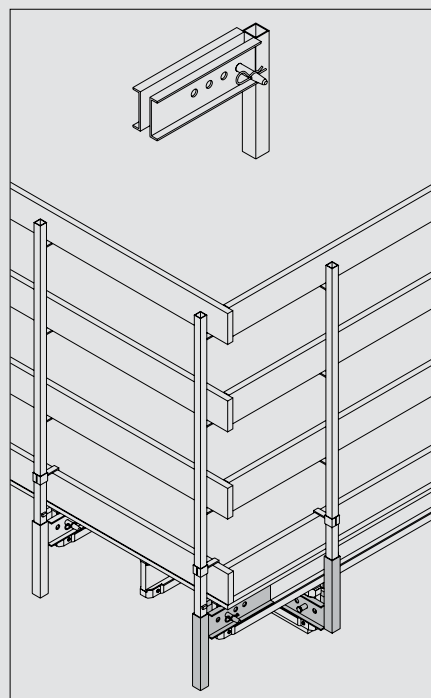

PD 8 Shoring System in use



Tun Razak Exchange Station, Kuala Lumpur

TRX is an iconic 70-hectare development in the heart of Kuala Lumpur which is aiming to become an international financial and economic hub in order to promote Malaysia as the new core of global economic growth.

Strategically located at the southern gateway to downtown Kuala Lumpur, TRX is flanked by major roadways. It has excellent accessibility and trans-

port connections via an integrated interchange railway station.

The TRX infrastructure project runs underground at a depth of 14.00 m. The twin-tube tunnel with a rectangular cross-section was realized using the cut-and-cover construction method.

PERI engineers developed a customer-specific formwork carriage consisting of rentable system components from the VARIOKIT Engineering Construction Kit and delivered formwork

and scaffolding from a single source. With this customized project solution, the construction crew maintained a 3-week cycle. PD 8 elements were connected to the slab tables to form larger units which could be moved very quickly to the next place of use. Diagonal bracing in different dimensions allowed polygonal adaptation in order to suit the course of the tunnel.



The following pages show a number of application examples and implementation possibilities of PD 8 Shoring in multi-storey, industrial and infrastructure construction.

PD 8 Shoring System in use

Application examples in multi-storey and industrial buildings



The PD 8 Shoring was the most cost-effective solution for forming the wide-spanded coffered ceilings with the large room heights of over 4 m.



PD 8 Shoring as a safe solution for clear heights of up to 8.50 m.



The PD 8 System was easy to assemble and thus enhanced the productivity of the team.

King Hussein Clinic, Amman, Jordan

The newly constructed medical centre is situated on a ridge close to the Jordanian state capital and the Dead Sea. On 120.000 m², the complex offers space for over 300 beds, out-patient treatment premises, a general care unit for the elderly, accommodation for the nursing staff as well as research facilities and a conference centre. Around 3,500 people work here focusing on the research and treatment of various forms of cancer.

The 7-storey main building has a surface area of 170 m x 200 m and is 30 m high. For forming the floor slabs, PERI's Turkish engineers chose to use PD 8 Shoring positioned under pre-assembled slab tables with dimensions of 4.50 m x 2.90 m. This ensured fast moving times for the over 4 m high rooms: horizontally using the Trolley and Winch, vertically with the PERI Lifting Fork.

Greenwich Drive Warehouse, Singapore

The new four-storey storage facility expands Keppel's warehouse capacity in Singapore by more than 32,000 m². This increases the capacity by 20% to more than 20 million m². The air freight logistics centre designed in an environmentally friendly way has automated storage, tracking and handling systems. The combination of these features leads to more efficiency, productivity and sustainability.

With a height of 9.50 m, stability was the greatest challenge during the moving procedure. Through the use of the PD 8 Shoring System, large movable units were realized for cost-effective forming. In order to ensure safe handling on site, PERI supervisors also trained the client's construction team to correctly handle the tables.

Modernization of the Sohar Refinery, Sohar, Sultanate of Oman

Orpic invested several billion dollars in the modernization of the Sohar refinery in the Sultanate of Oman.

The modernization was carried out to further maximize the value of Omani crude oil and increase the production output by 70%.

The 970 m² slab area with a thickness of 2 m was unique in its construction as no intermediate supports were required. In order to be able to support such a large area at a height of 31 m, 31,000 m³ of PD 8 Shoring was used. The high load-bearing capacity and cost-effectiveness of the system made it the perfect choice for the ambitious project.



Etihad Towers, Abu Dhabi, United Arab Emirates

PD 8 Shoring System in use

Application examples in infrastructure construction



PD 8 Shoring could be quickly and flexibly adapted to suit the different slab heights.



Shoring towers were quickly and easily mounted with only a minimum of personnel whereby the PD 8 Shoring reliably transferred the high loads into the ground.



The high load-bearing capacity of the PD 8 System in connection with steel walers as main beams facilitated cost-effective working.

PRIMAX, 22 New Industrial Road, Singapore

PRIMAX is an industrial area located on the New Industrial Road in District 19. It is mainly used by light manufacturing businesses.

After the elevator shafts and the walls of the stairwell were formed with the help of VARIO GT 24 Wall Formwork and CB 240 Climbing Systems, VARIO GT 24 Column Formwork was used for concreting the columns of the building.

Thanks to the infinitely variable height adjustment of the PD 8 Shoring by means of spindles and frames, the reinforced concrete slab could be concreted at heights of 3.50 m through to 7.00 m.

Together with the contractor, PERI engineers already planned in advance the possibility of re-using the prefabricated column and table formwork. This ensured that the formwork could be re-used in the next section.

Midfield Terminal, Abu Dhabi, United Arab Emirates

The centrepiece of the Terminal is the over 50 m high passenger terminal, the so-called Central Processor. The building has a total area of 700,000 m² distributed over seven floors.

Some 6,200 slab tables were in continuous construction site use as only 18 months had been scheduled for completion of the Central Processor shell. Within a very short time, over 60,000 robust stacking frames of the proven PD 8 Shoring System were delivered to the jobsite. The slabs together with the massive, mostly 0.85 m wide and 1.10 m high beams were constructed in one pour.

PERI formwork requirements amounted to almost 65,000 m². Delivery of enormous amounts of materials at short notice as well as competent engineering with related formwork and scaffolding planning made a convincing case during the construction of the airport terminal of unparalleled proportions.

Rabat-Iteen Motorway Interchange, Salalah, Sultanate of Oman

The plan was to partially extend the existing Rabat-Iteen motorway interchange to form a cloverleaf junction. In order not to present any additional risk to the surrounding roads, all work that took place during ongoing road traffic was carried out as simple as possible. Thanks to the high level of cost-effectiveness and very safe working conditions, PERI formwork and scaffolding systems were therefore used.

Contractor SMC Infra decided in favour of the PD 8 Shoring System in order to support the special bridge formwork. The combination of the MULTIFLEX Girder Slab Formwork with GT 24 Girders allowed greater spans to be formed. As a result, the number of components that had to be moved – as well as the danger to the surrounding area – was reduced. Combined with the efficiency of the PERI systems, it was possible to concrete in only two steps: the trough area was realized first, followed by the carriageway. This resulted in a considerable increase in the on-site effectiveness.

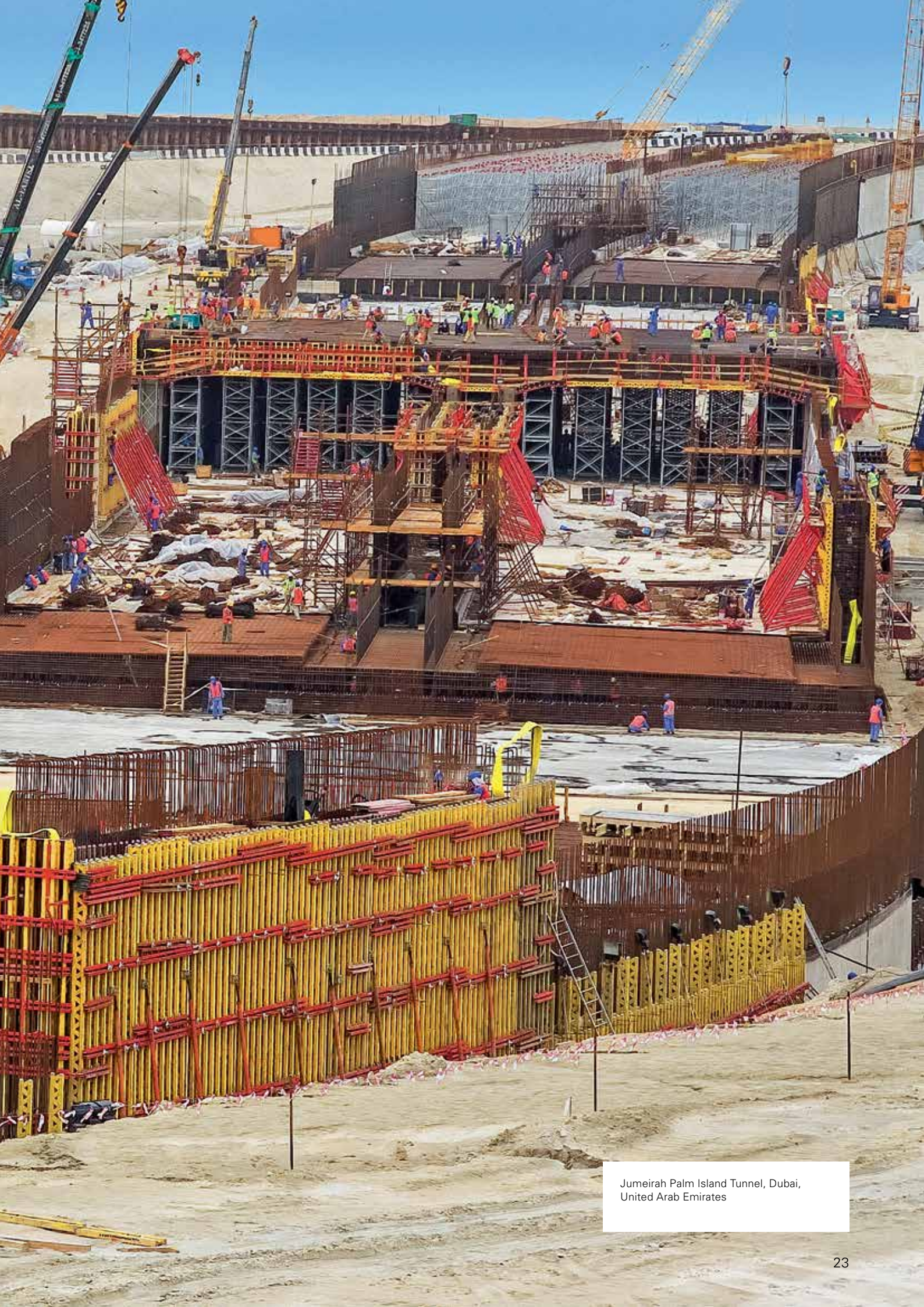

Jumeirah Palm Island Tunnel, Dubai,
United Arab Emirates

PD 8 Slab Table



Item no.	Weight kg
018510	32.600
018520	27.100

Frames PD 8, galv.

Frame PD 8, R 150, galv.

Frame PD 8, R 110, galv.

Base frame for PD 8 Table Form, Shoring Tower and Stair Tower.

Note

Permissible load see PERI Design Tables.

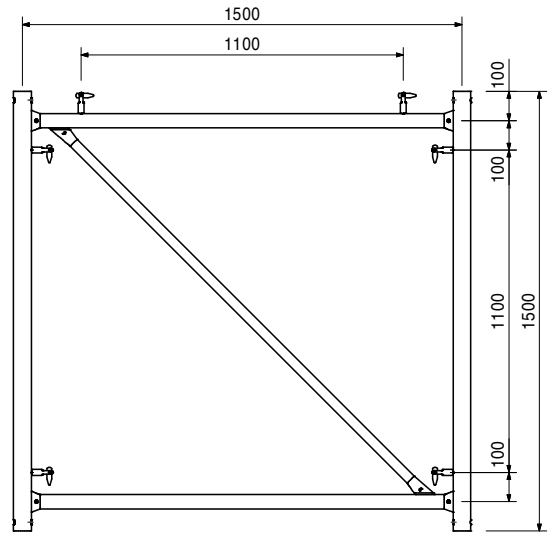
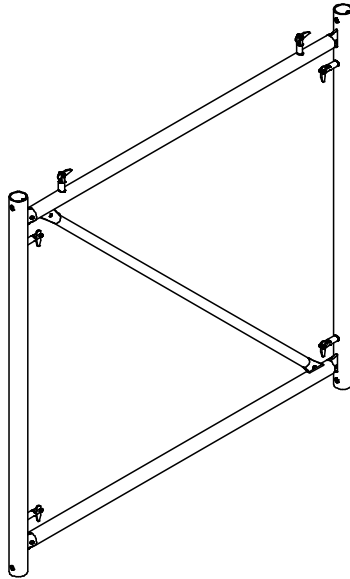

018140	0.551
--------	-------

Accessories

Connector with Washer, galv.

018140	0.551
--------	-------

Connector with Washer, galv.

To connect frames R 180, R 150 and R 110.

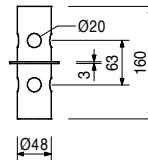

018050	0.171
018060	0.030

Accessories

Pin Ø 16 x 65/86, galv.

Cotter Pin 4/1, galv.

PD 8 Slab Table

Item no.	Weight kg
018150	7.530
018160	8.390
018170	10.200
018180	12.200
018190	14.300
018200	16.400

Diagonal Braces DK, galv.
Diagonal Brace DK 125, galv.
Diagonal Brace DK 150, galv.
Diagonal Brace DK 200, galv.
Diagonal Brace DK 250, galv.
Diagonal Brace DK 300, galv.
Diagonal Brace DK 350, galv.

L	X	Y
1665	1250	1100
1860	1500	1100
2282	2000	1100
2731	2500	1100
3195	3000	1100
3668	3500	1100

For bracing of PD 8 Slab Tables. Frame combination R 150 + R 150 or R 150 + R 110.

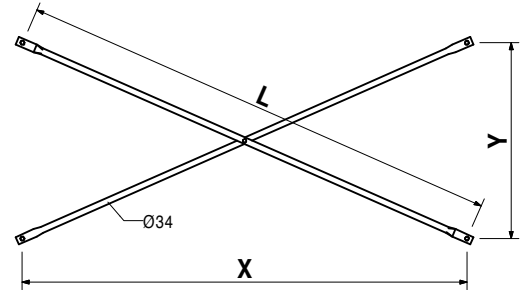
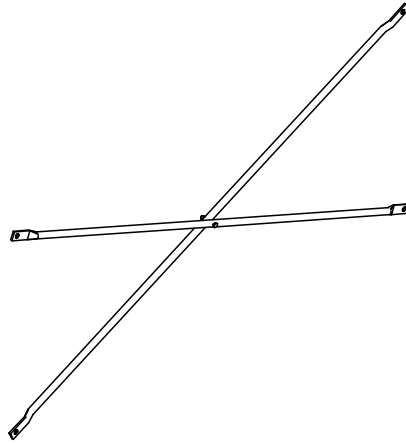

019150	6.510
019160	7.490
019170	9.550
019180	11.600
019190	13.800

Diagonal Braces DK, R 110, galv.
Diagonal Brace DK 125/110, galv.
Diagonal Brace DK 150/110, galv.
Diagonal Brace DK 200/110, galv.
Diagonal Brace DK 250/110, galv.
Diagonal Brace DK 300/110, galv.

L	X	Y
1433	1250	700
1655	1500	700
2118	2000	700
2596	2500	700
3080	3000	700

For bracing of PD 8 frames in the combination R 110 + R 110.

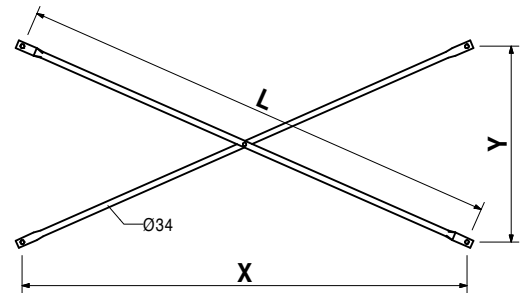
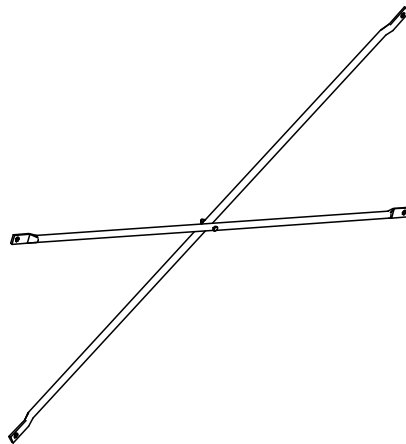

Item no.	Weight kg
----------	-----------

018120	4.400
018030	6.820

Spindle Tubes TR 48, galv.
Spindle Tube TR 48-75/40, galv.
Spindle Tube TR 48-116/80, galv.
 For use as head and base spindle for the PD 8 Systems and Flex Plus Shoring.

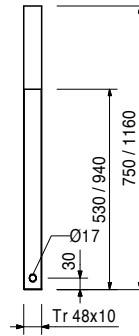

Accessories

127604	1.270
--------	-------

Quick Jack Nut TR 48-2, galv.

318270	0.800
--------	-------

Quick Jack Nut TR 48, galv.

For spindles Ø 48 mm.

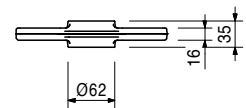
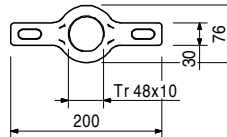
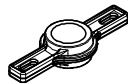

127604	1.270
--------	-------

Quick Jack Nut TR 48-2, galv.

For spindles Ø 48 mm; with additional groove.

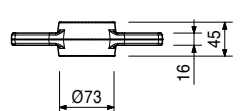
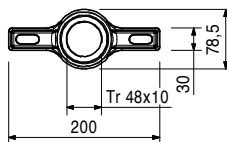
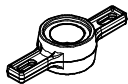

018070	1.770
--------	-------

Base Plate for Spindle Tube TR 48

Base plate for Spindle Tubes and Foot Tube FR 80.

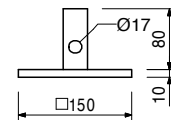
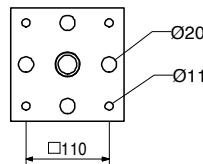
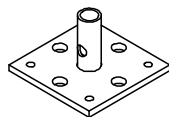

Accessories

018050	0.171
018060	0.030

Pin Ø 16 x 65/86, galv.
Cotter Pin 4/1, galv.

PD 8 Slab Table

Item no.	Weight kg
018040	3.770

Head Plate for Spindle Tube TR 48

Note

Can be pivoted by 2.1 % in combination with Cap Piece.

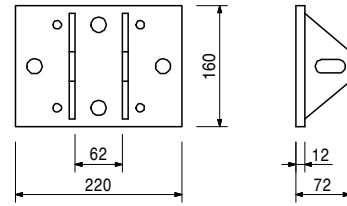

Accessories

018050	0.171	Pin Ø 16 x 65/86, galv.
018060	0.030	Cotter Pin 4/1, galv.
019660	0.288	Cap Piece, galv.

018050	0.171	Pin Ø 16 x 65/86, galv. For different connections.
--------	-------	--------------------------------------------------------------

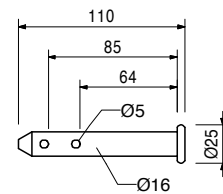
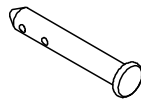

Accessories

018060	0.030	Cotter Pin 4/1, galv.
--------	-------	------------------------------

018060	0.030	Cotter Pin 4/1, galv.
--------	-------	------------------------------



019660	0.288	Cap Piece, galv. For centric load application. Allows 2.1% inclination of the head plate.
--------	-------	-----------------------------------------------------------------------------------------------------

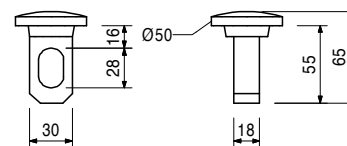
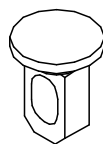

PD 8 Slab Table



Item no.	Weight kg
018630	9.500

Cross Head Spindle TR 48-75/47, galv.
Head spindle for PD 8 Slab Table and Flex Plus Shoring.

Complete with
1 pc. 018270 Quick Jack Nut TR 48, galv.

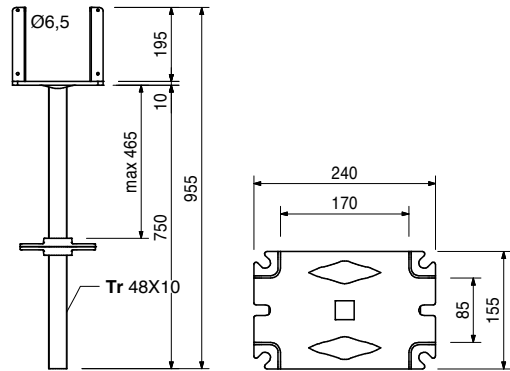
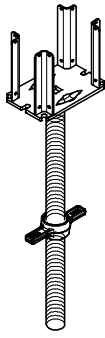

Accessories

028590	0.568
--------	-------

Tension Strap 16-25, galv.

116767	0.144
--------	-------

Safety Strap for PD 8 Table
To secure the base and head spindles at PD 8 Slab Table, yellow chromatised.

Technical Data
Permissible load-bearing capacity 300 kg.

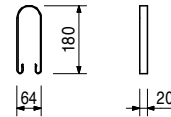

019200	162.000
--------	---------

Trolley with Winch
For moving towers and tables with MULTIPROP, Flex, Flex Plus and PD 8 with appropriate support for the system.

Note
Follow Instructions for Use!
Technical Data
Permissible load-bearing capacity 1.0 t.

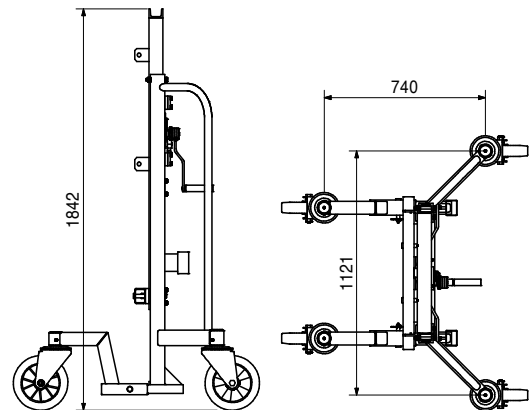
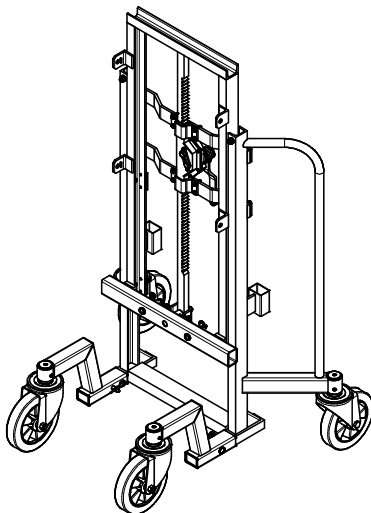

Accessories

118114	14.200
118115	11.000
130501	27.600

Connector MP - Trolley
Connector PD 8 - Trolley
Connector PERI UP - Trolley

PD 8 Slab Table



Item no.	Weight kg
118115	11.000

Connector PD 8 - Trolley

For moving PD 8/PD 8 Eco Systems with Trolley with Winch.

Note

Consisting of 2 parts:
Support left and right.

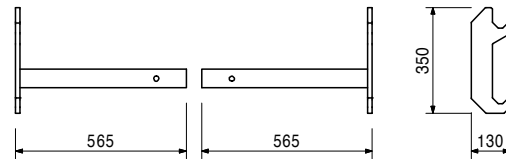
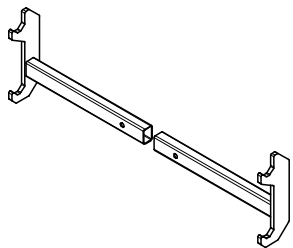

019070	1.400
--------	-------

Crane Lifting Unit, Lower Part - PD 8

For moving PERI PD 8 Slab Tables with Main Beam SRZ.

Complete with

2 pc. 018060 Cotter Pin 4/1, galv.
1 pc. 018050 Pin \varnothing 16 x 65/86, galv.

Technical Data

Load-bearing point: capacity 0.5 t.

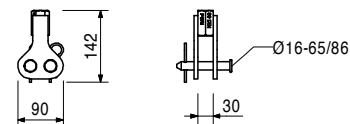

028570	3.510
--------	-------

Crane Lifting Unit, Upper Part

For moving PERI Slab Tables with GT 24 Main Beam. Attachment point for folding the working platform.

Note

Follow Instructions for Use!

Technical Data

Permissible load-bearing capacity 0.5 t with crane sling angle $\leq 30^\circ$.

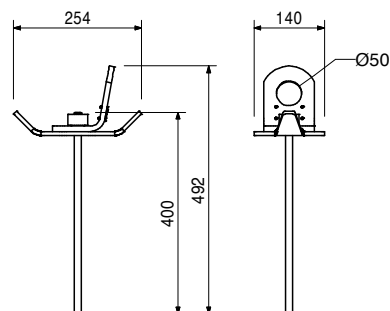
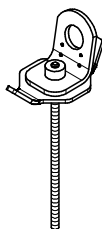

018090	0.265
--------	-------

Screw-on Locking Angle ASW, galv.

For centering Profile U100 and U120 Steel Walers on the head plate with PD 8 Shoring Towers.

Note

2 pieces per head plate. With M16 nut.

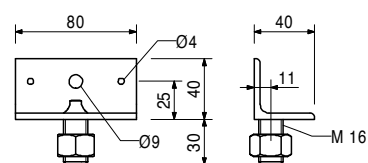
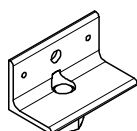

Item no. Weight kg

018050 0.171

Pin Ø 16 x 65/86, galv.
For different connections.

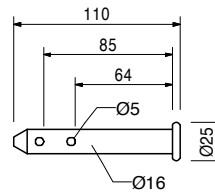
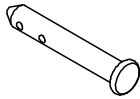

Accessories

018060 0.030

Cotter Pin 4/1, galv.

018060 0.030

Cotter Pin 4/1, galv.

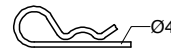

018350 0.310

Bolt ISO 4016 M16 x 160-4.6 MU, galv.

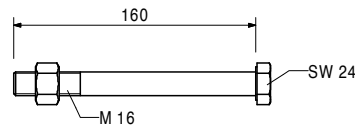
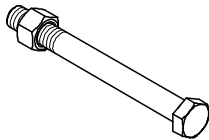

024060 0.107

Girder Strap TB, galv.

For mounting main beams on the Head Plate PD 8.

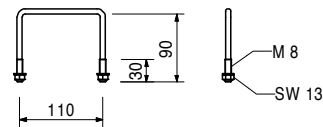
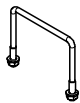

024010 0.338

Double Girder Strap DTB, galv.

For mounting main beams on the Head Plate PD 8.

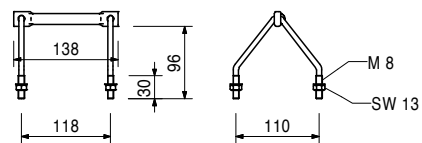
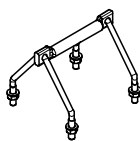

Item no.	Weight kg
018600	1.190

Yoke Plate, galv.

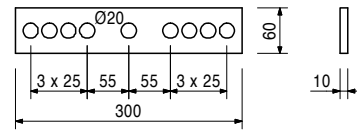
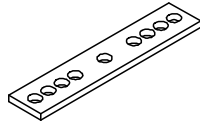

018300	0.564
--------	-------

Cross Strap, galv.

For fixing Steel Walers SRZ and SRU on the Head Spindle TR 38.

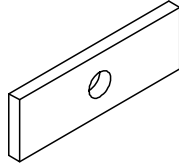

Accessories

018350	0.310
--------	-------

Bolt ISO 4016 M16 x 160-4.6 MU, galv.

018610	0.550
--------	-------

Yoke Clamp 24

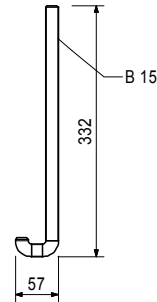

030130	0.318
--------	-------

Cam Nut DW 15, galv.

For anchoring with Tie Rod DW 15 and B 15.

Technical Data

Permissible load 90 kN.

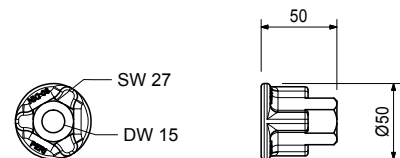
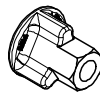

**The optimal System
for every Project and
every Requirement**



Wall Formwork



Column Formwork



Slab Formwork



Climbing Systems



Bridge Formwork



Tunnel Formwork



Shoring Systems



Construction Scaffold



Facade Scaffold



Industrial Scaffold



Access



Protection Scaffold



Safety Systems



**System-Independent
Accessories**



Services



PERI GmbH
Formwork Scaffolding Engineering
 Rudolf-Diesel-Strasse 19
 89264 Weissenhorn
 Germany
 Tel. +49 (0)7309.950-0
 Fax +49 (0)7309.951-0
 info@peri.com
 www.peri.com

